

SAFETY RECALL NOTICE

VOLVO

IMPORTANT SAFETY RECALL RVXX1504 NHTSA RECALL # 15V-524

DEAR VOLVO TRUCK OWNER:

This notice is sent to you in accordance with the requirements of the National Traffic and Motor Vehicle Safety Act.

Volvo Trucks North America has decided that a defect which relates to motor vehicle safety exists in certain Volvo 2012- 2015 VNL and VNM model trucks with a trailer hand brake built between May 31, 2011 and December 1, 2014.

SAFETY DEFECT: The cut out in the trim panel may restrict the trailer hand brake handle from returning to the off position.

SAFETY RISK: The trailer service brakes may drag, which can cause the wheel end to overheat and potentially cause a wheel end fire or tire blowout which could result in a crash.

PRECAUTIONS YOU CAN TAKE: Owners are being provided inspection instructions and given the choice of conducting the inspection for the defective trim panel themselves (see attached) or having their vehicle inspected by a Volvo Parts and Service Center.

TIME REQUIRED FOR THE REPAIR: The time required to repair your vehicle is approximately 2 hours.

WHAT YOU SHOULD DO: For those customers that elect to perform the inspection themselves, please proceed to the inspection procedure on the following pages. If defective, you should contact the nearest Volvo Parts and Service Center and make an appointment. The trim panel will be replaced if defective at **no charge** to you.

You can locate the closest Volvo Parts and Service Center by going on line to <http://www.volvo.com/trucks/na/en-us/dealers/> and selecting "Dealer Locator" or by calling our toll-free number: (800) 528-6586.

**NOTICE REGARDING
LEASED VEHICLES:**

If you are a Lessor of vehicles subject to this Notice, you have an obligation under Federal Law to provide a copy of this Notice to all Lessees within 10 days of your receipt of this Notice. Further, you must maintain a record, which identifies the Lessee(s) to whom you send a copy of this letter, the date you send this letter, and the Vehicle Identification Number(s) of the vehicle(s) that you have leased to that lessee. For purposes of this Notice, the term Lessor means: a person or entity that is the owner, as reflected on the vehicle's title, of any five or more leased vehicles (as defined in CFR Section 577.4), as of the date of notification by the manufacturer of the existence of a safety-related defect or non-compliance with a Federal Motor Vehicle Safety Standard in one or more of the leased motor vehicles.

**OWNER RECALL
RESPONSE CARD:**

The enclosed "Notice of Vehicle Recall" identifies your vehicle. If you no longer own the vehicle, please help us update our records by completing the "Vehicle Disposition Record" portion of the enclosed postage-free Notice of Mandatory Safety Campaign card and mailing it back to us.

**ASSISTANCE/
COMPLAINTS:**

If your vehicle has not been repaired within a reasonable time after delivering it to a Volvo Parts and Service Center, please contact:

Volvo Trucks North America
Regulatory Affairs Department,
P.O. Box 26115
Greensboro, NC 27402-6115
vtna.regulatoryaffairs@volvo.com

You may also submit complaints to the Administrator of the National Highway Traffic Safety Administration (1200 New Jersey Avenue, S.E., Washington DC 20590 or call the toll-free Auto Safety Hot Line at 1-888-327-4236 (TTY: 1-800-424-9153), or go to <http://www.safercar.gov> if you believe that Volvo has failed to remedy the defect without charge, or has failed to remedy the vehicle within 60 days of the owners first tender to obtain repair following the earliest time that parts are available.

**PRE NOTIFICATION
REMEDIES:**

If you have previously paid for repairs as a result of this issue, you may be entitled to recovery of those expenses.

Submit copies of all documentation supporting your claim according to the rules specified in the "General Plan for Reimbursement of Pre-notification Remedies" provided in this mailing.

We regret any inconvenience this may cause to your operation, but hope you will appreciate our sincere efforts to demonstrate Volvo's commitment to provide our customers with the best possible product.

VOLVO TRUCKS NORTH AMERICA

SAFETY RECALL

Volvo Trucks North America
Greensboro, NC USA

VOLVO

Trailer Hand Brake Trim Panel, VN

INSPECTION:

Decommissioning the Truck for Inspection or Repair:

1. Secure the vehicle for service by parking on a flat and level surface, placing the transmission in neutral, applying the parking brake, turning the ignition key to the OFF position, and chocking the front wheels.

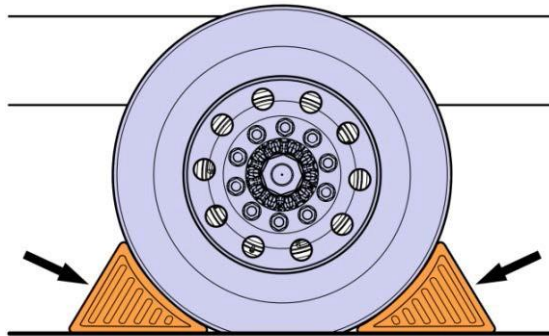

2. Disconnect the cable from the battery's negative (ground) terminal.

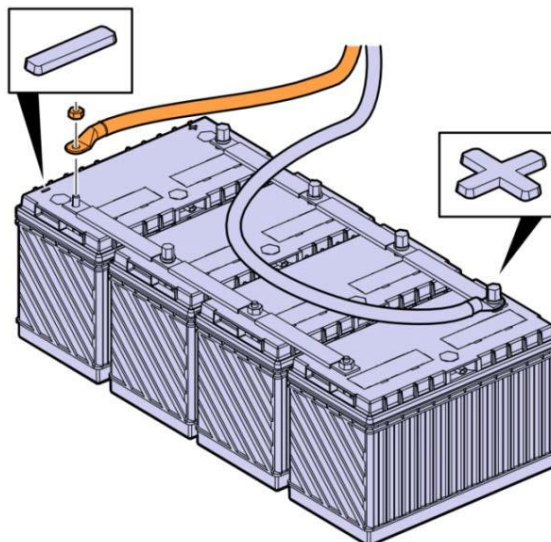

Trailer Hand Brake Trim Panel, Inspection Procedure:

NOTE

The Illustrations shown in this document are used for reference only and may differ slightly from the actual vehicle being serviced. However, the replacement procedure is represented as accurately as possible.

1. Using a micrometer, measure the length of slot surrounding the trailer hand brake in the trim panel to determine if replacement of the trim panel is necessary.
2. If the slot in the trim panel is equal to or less than 59 mm then replacement is required, please arrange for this activity to be completed.

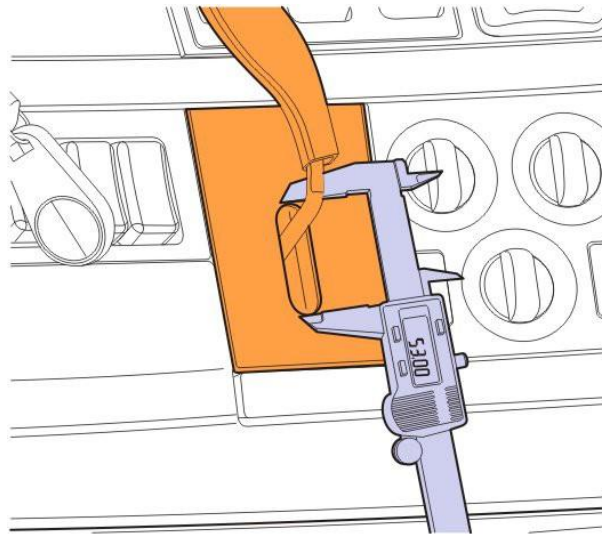

3. If the slot in the trim panel is greater than 59mm, then replacement of the part is not required. Please proceed to commission the vehicle and fill in and return the customer response card. (sample below)

VOLVO TRUCKS

THIS NOTICE APPLIES TO YOUR VEHICLE

MODEL	VEHICLE IDENTIFICATION NUMBER	BR./ DIST. CODE	RECALL NUMBER

DEALER NAME

DEALER ADDRESS

DEALER CITY & STATE

Volvo Safety Recall RVXX1504, Trailer Hand Brake/ Trim Panel

I certify that I have inspected the trim panel on this vehicle as directed by the Inspection Instructions and have found the following.

The trim panel is the correct length per the inspection instructions. Trim panel is incorrect and will be taken to the dealer for replacement.

Model _____ VIN # _____

OWNER/COMPANY NAME _____ AUTHORIZED SIGNATURE AND DATE _____

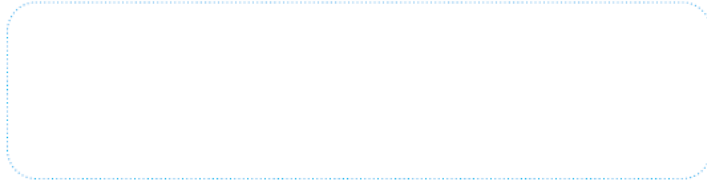

This postage-free reply card is to be used to report a change in vehicle ownership or any other change in vehicle disposition. If such a change has occurred, please help us update our records by completing the left-hand portion of this form and drop it in the mail. Postage will be paid by Volvo Trucks North America.



Please remove this stub at the perforation before mailing.

Commissioning the Truck for Operation:

1. Connect the battery cable to the negative (ground) terminal.

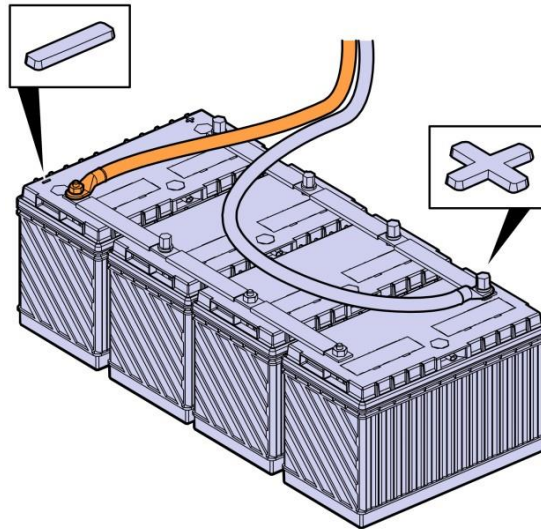

2. Remove the wheel chocks.

